

2400...2500 MHz / 5150...7125 MHz PCB Antenna (ISM, IoT, Bluetooth, WLAN, Wi-Fi 5/6/6E)

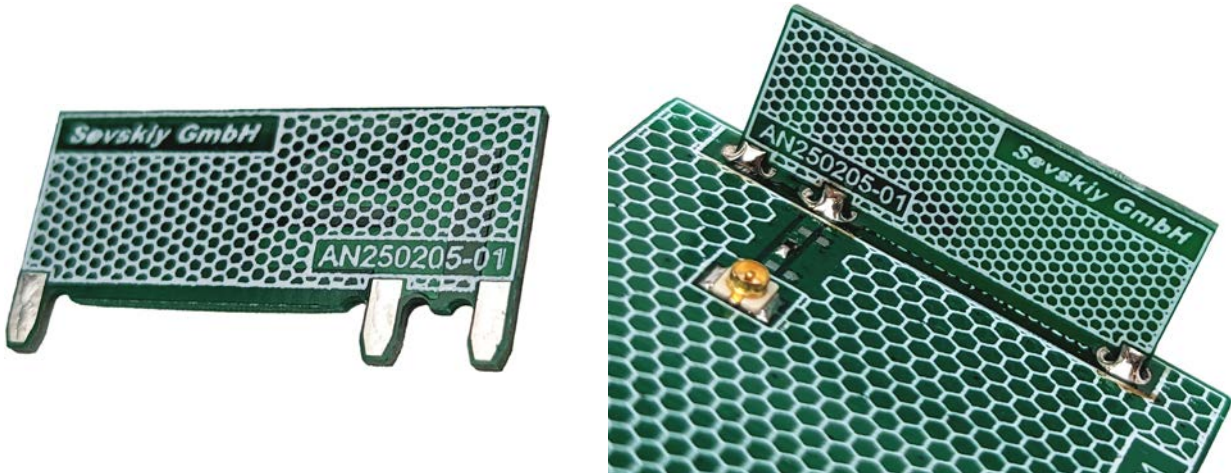

#### General information

This compact embedded PCB antenna is designed for multi-band wireless operation in the 2.4 GHz, 5 GHz, and 7 GHz frequency ranges, supporting ISM, Bluetooth, WLAN, and Wi-Fi 5/6/6E standards. It delivers reliable RF performance across a wide range of short-range and high-throughput wireless communication systems, including both legacy and next-generation Wi-Fi networks. This antenna is particularly suitable for integration into modern routers, gateways, access points, IoT devices, smart home and smart building equipment, as well as compact wireless communication modules.

The antenna is manufactured on a PCB and equipped with three contacts for vertical solder mounting along the edge of the device's primary circuit board. A corresponding footprint must be included to provide both mechanical stability and proper electrical connection. Once installed, the antenna stands perpendicular to the main board, ensuring reliable performance even in compact enclosures.

#### Electrical data

Antenna type	Embedded / internal antenna soldered on the main PCB	
Frequency band	ISM2400, Wi-Fi 2.45 / 5.5 / 6.5 GHz, ISM5800	
Frequency range [MHz]	2400...2500	5150...7125
Return loss [dB] <sup>1)</sup>	-15	-10
Peak gain [dBi]	2.5	2.5...4
Radiation efficiency [%]	90	50...90
Nominal input impedance [Ohm]	50	
Polarization	linear	
Radiation pattern	omnidirectional	
Maximum input power [W]	5	

#### Mechanical data

Antenna PCB dimensions [mm]	25 x 12.5 x 0.8
PCB material	FR4
Weight [g]	0.45

#### Additional information

All electrical data have been obtained in free space on the reference board (not included) with the following dimensions: 50mm x 35mm x 0.8mm. Please note that the performance in the lower frequency bands is dependent on the ground plane length and may degrade in case of reducing the board size.

Other mechanical designs, materials or frequency bands are possible on request.

Further customization, electromagnetic simulations and measurements can be offered on request.

*All information (including technical data and pictures) presented in this document is typical and subject to change without notice. Sevskiy is a registered trade mark of Sevskiy GmbH. Copyright © 2009 - 2026 Sevskiy GmbH. All rights reserved. No warranties.*

2400...2500 MHz / 5150...7125 MHz PCB Antenna (ISM, IoT, Bluetooth, WLAN, Wi-Fi 5/6/6E)

Measured input impedance matching

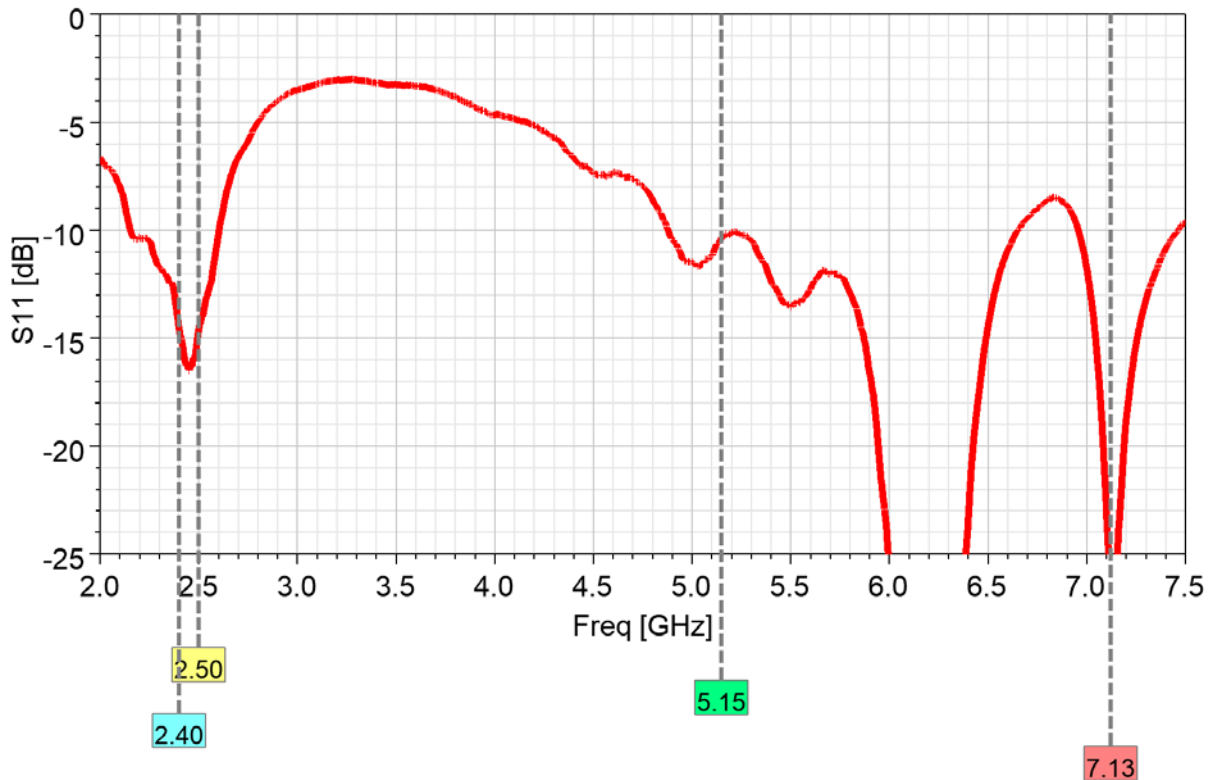

VSWR

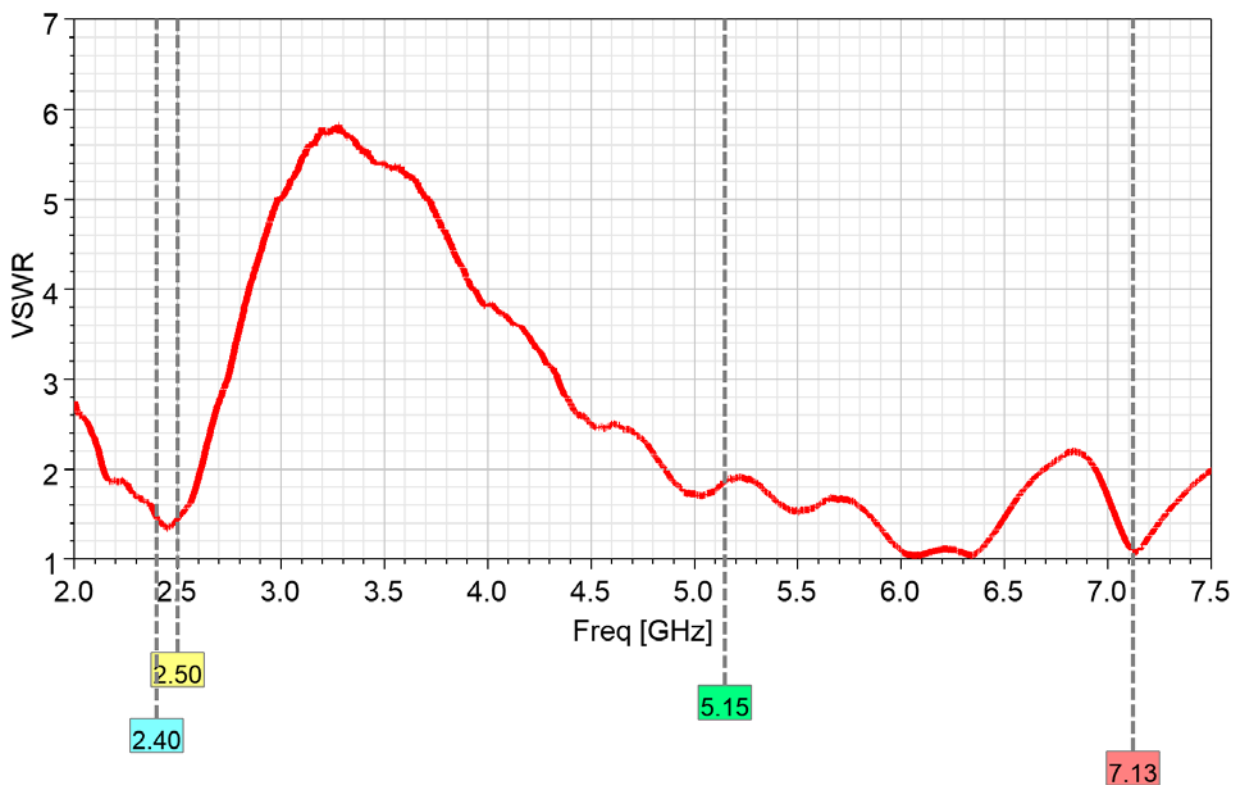

All information (including technical data and pictures) presented in this document is typical and subject to change without notice. Sevskiy is a registered trade mark of Sevskiy GmbH. Copyright © 2009 - 2026 Sevskiy GmbH. All rights reserved. No warranties.

2400...2500 MHz / 5150...7125 MHz PCB Antenna (ISM, IoT, Bluetooth, WLAN, Wi-Fi 5/6/6E)

Peak realized gain

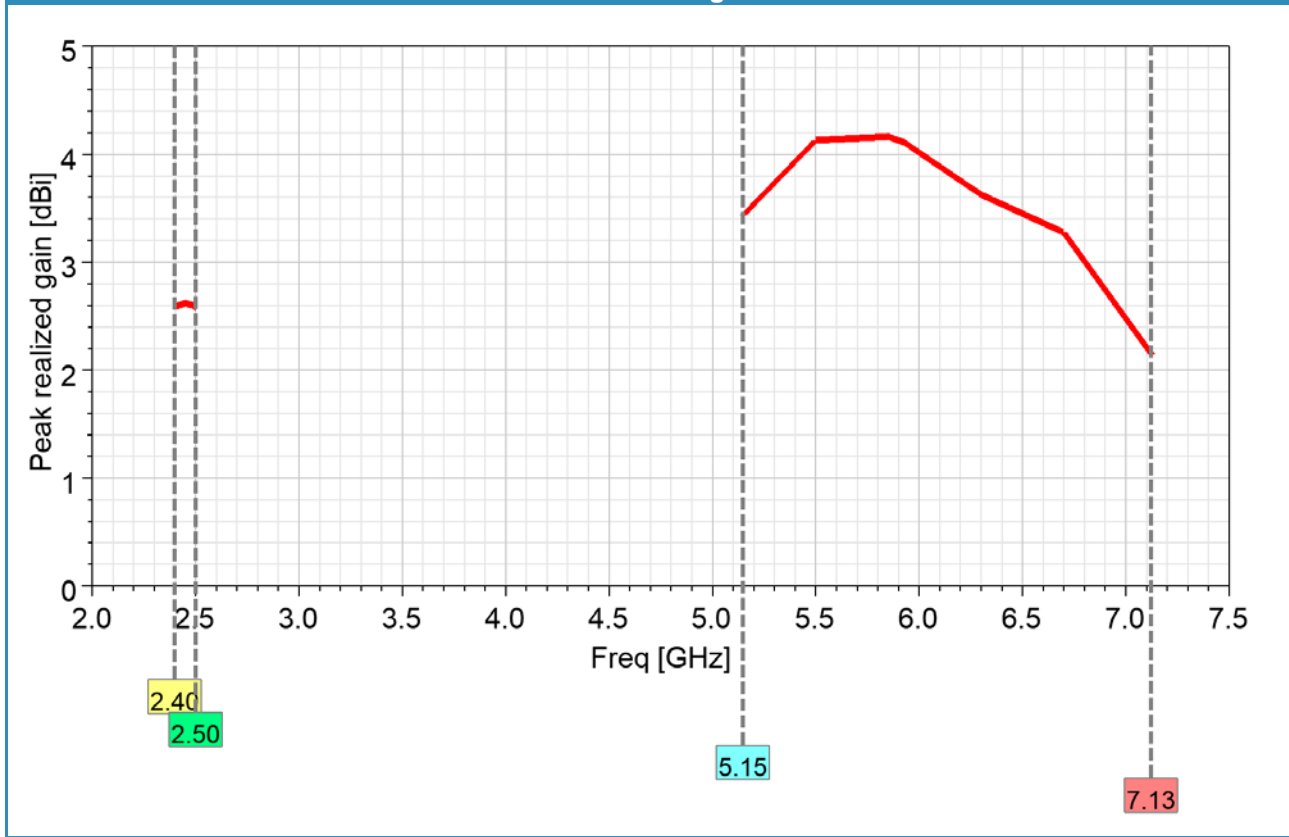

Radiation efficiency

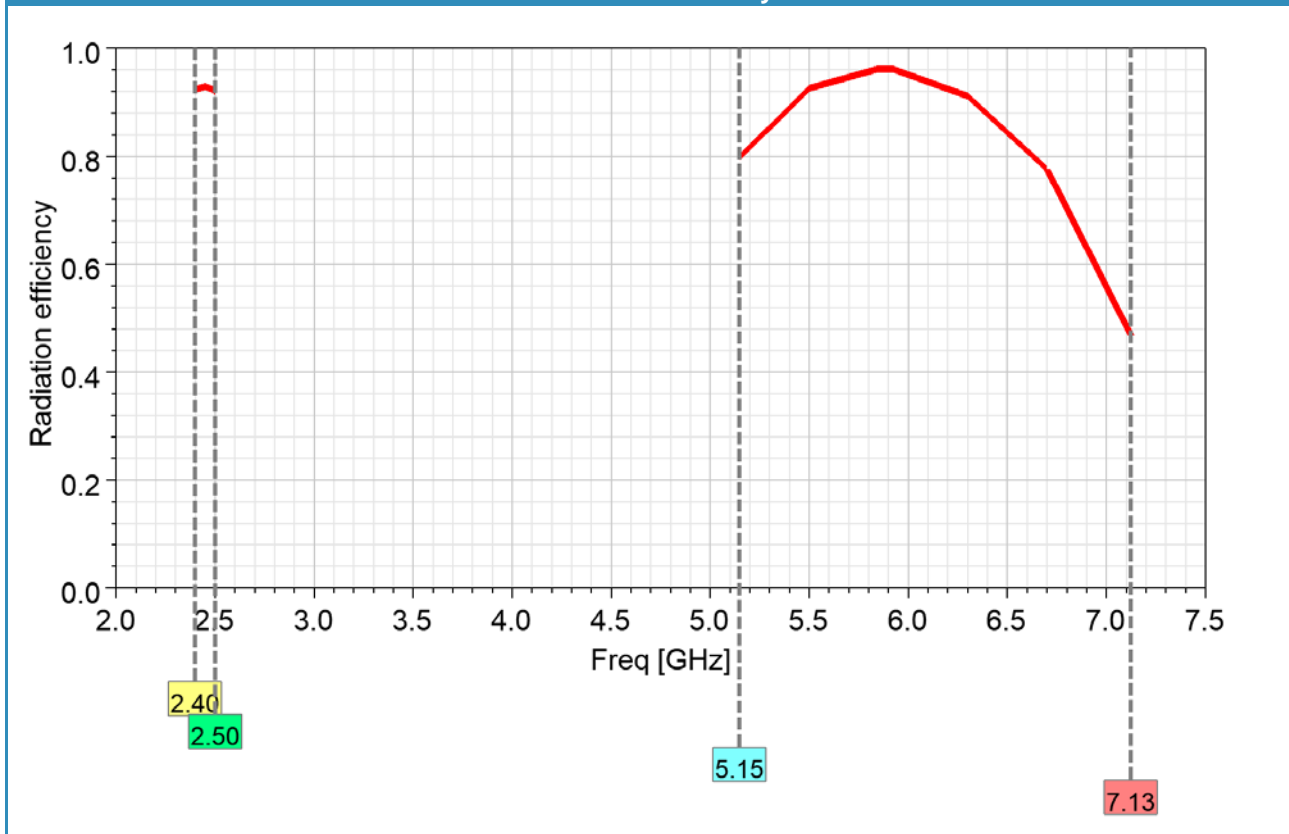

All information (including technical data and pictures) presented in this document is typical and subject to change without notice. Sevskiy is a registered trade mark of Sevskiy GmbH. Copyright © 2009 - 2026 Sevskiy GmbH. All rights reserved. No warranties.

**2400...2500 MHz / 5150...7125 MHz PCB Antenna (ISM, IoT, Bluetooth, WLAN, Wi-Fi 5/6/6E)**

**Radiation pattern**

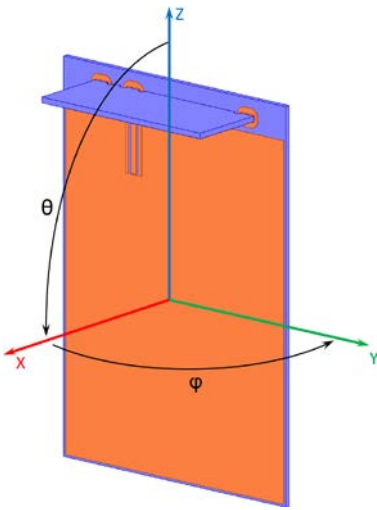

Total realized gain [dBi]  
 Phi=0°, plane XZ, green curve  
 Phi=90°, plane YZ, red curve  
 Theta=90°, plane XY, blue curve

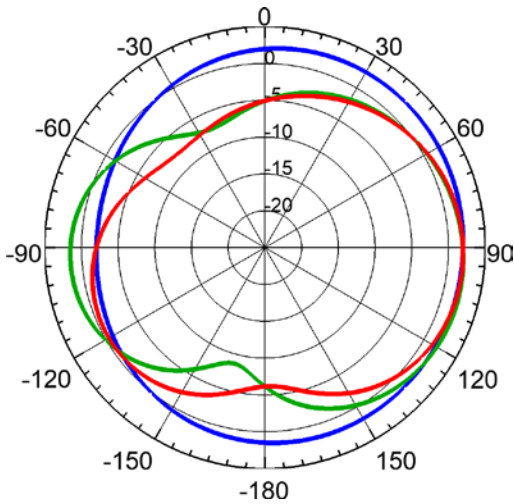

2450 MHz

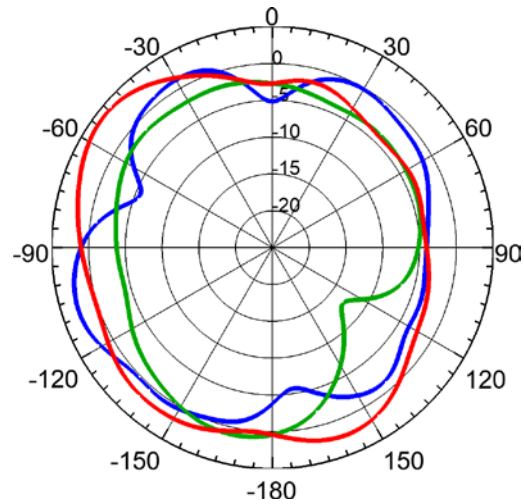

5500 MHz

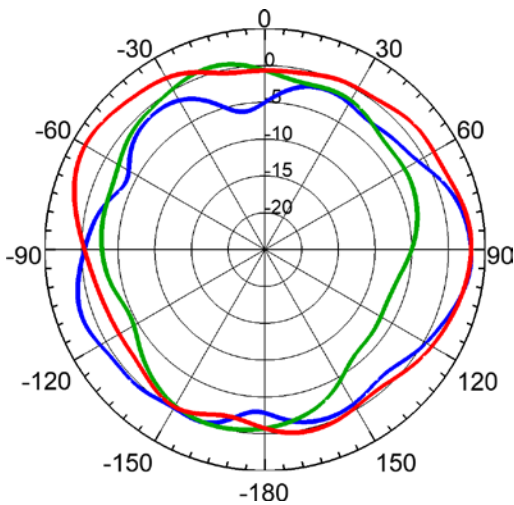

6300 MHz

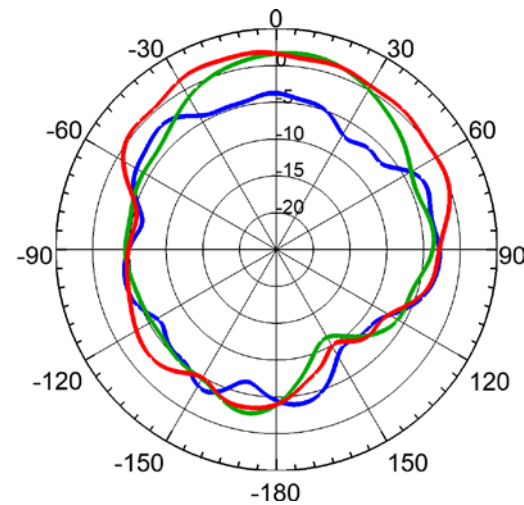

7125 MHz

All information (including technical data and pictures) presented in this document is typical and subject to change without notice. Sevskiy is a registered trade mark of Sevskiy GmbH. Copyright © 2009 - 2026 Sevskiy GmbH. All rights reserved. No warranties.

2400...2500 MHz / 5150...7125 MHz PCB Antenna (ISM, IoT, Bluetooth, WLAN, Wi-Fi 5/6/6E)

**Product dimensions and recommended layout**

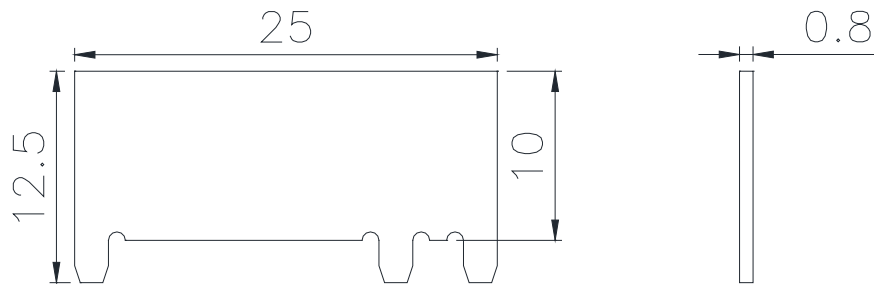

Top layer

Bottom layer

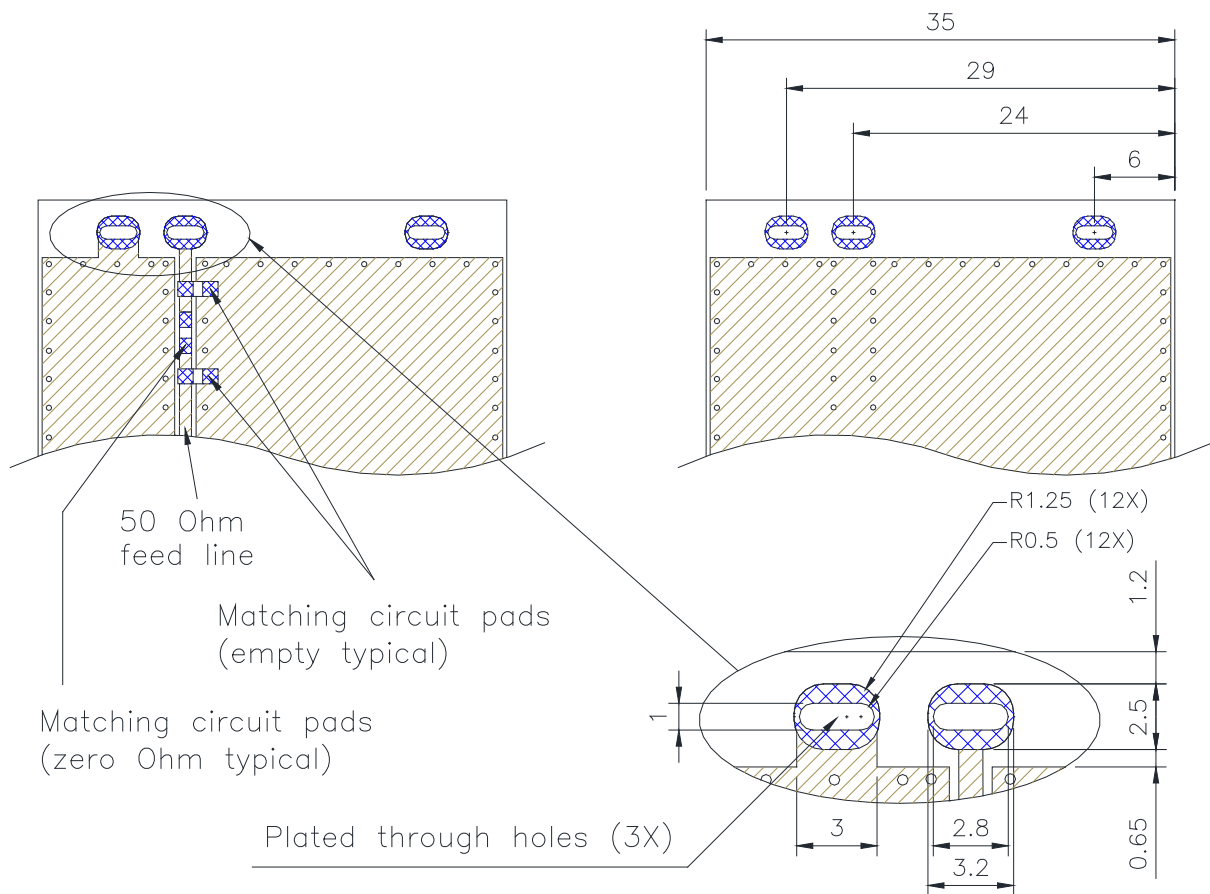

Copper



Free solder mask area

Unit: mm

All information (including technical data and pictures) presented in this document is typical and subject to change without notice. Sevskiy is a registered trade mark of Sevskiy GmbH. Copyright © 2009 - 2026 Sevskiy GmbH. All rights reserved. No warranties.

2400...2500 MHz / 5150...7125 MHz PCB Antenna (ISM, IoT, Bluetooth, WLAN, Wi-Fi 5/6/6E)

**Antenna placement**

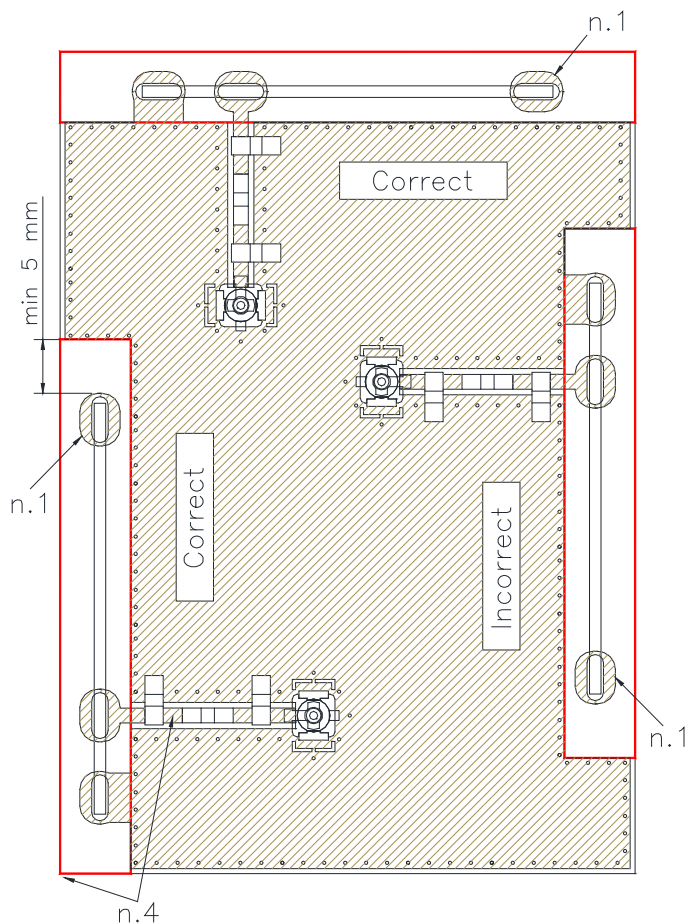

-  Copper
-  Copper keep-out area through the all PCB layers

Notes:

1. Mechanical mounting pads (without GND connection)
2. Reference board size: 50x35mm
3. Antenna must be mounted on the PCB board edge
4. The feedline should be placed as close as possible to the PCB corner

All information (including technical data and pictures) presented in this document is typical and subject to change without notice. Sevskiy is a registered trade mark of Sevskiy GmbH. Copyright © 2009 - 2026 Sevskiy GmbH. All rights reserved. No warranties.